

Laser Focus World®

PennWell®



TECHNICAL DIGEST

High-power fiber lasers: techniques and accessories

High-power continuous-wave fiber lasers have revolutionized many areas of manufacturing. As the technology matures, the techniques and accessories that aid the use of these lasers are growing ever-more sophisticated. In this tech digest, an overview of today's high-power fiber lasers is given, along with two modern developments in the technology: one relating to noncontact beam measurement, and the other to using multiple beams in materials processing.

SPONSORED BY:



2 High-power Fiber Lasers: Kilowatt-level fiber lasers mature

14 High-power fiber lasers drive noncontact-measurement techniques

19 Multiple laser beam materials processing

Photonics Products: High-power Fiber Lasers: Kilowatt-level fiber lasers mature

Although today's high-power CW fiber lasers have their origins in telecom technology, they have long since left that arena and become naturals at reliable, capable materials processing.

By **JOHN WALLACE**, Senior Editor

FIBER LASERS COMBINE active (laser-gain) optical fiber with one or more pump lasers, usually laser diodes. The many types of fiber lasers include low-power continuous-wave (CW) and low- and high-energy pulsed, including ultrafast fiber lasers. But what comes to mind for many people are the “big guns”—the kilowatt-class CW fiber lasers that are predominantly used in materials processing, including cutting, welding, brazing, surface treatment, and other applications, but are also being developed for the military as directed-energy weapons.

A fiber is essentially a very skinny, long rod—its configuration makes it one of two types of lasers that have an especially high surface area-to-volume ratio, making them easier to keep cool (the other is the disk laser—a wide, extremely short rod). Fiber lasers are relatively simple in their construction and are easy to maintain. They are compact and, because they are pumped with laser diodes, rugged and long-lived.

Large range of powers and wavelengths

Alexei Markevitch, market development manager at IPG Photonics (Oxford, MA), outlines the range of wavelengths and powers available for kilowatt-class fiber lasers. “IPG manufactures standard kilowatt-class CW lasers at 1 μm (ytterbium-doped fiber) and 1.5 μm (erbium-doped fiber) and also manufactures custom kilowatt-class lasers at 2 μm (thulium doped fiber), along with lasers that have Raman-shifted wavelengths between 1.1 and 1.7 μm ,” he says. “The longer wavelengths enable nonmetal materials processing and other new applications and are considered to be eye-safe, as the eye-damage threshold is many orders of magnitude higher than for 1 μm lasers.”

Markevitch notes that the kilowatt-class fiber laser systems operate in CW or modulated modes up to 5 kHz, and have dynamic range from 10% to full power with no change in beam divergence or beam profile.

At 1 μm , the company’s single-mode YLS-SM ytterbium-doped fiber lasers span a power range from 1 to 10 kW, says Markevitch. These single-mode systems are used in advanced materials-processing applications requiring extremely high power and brightness, such as fine cutting and surface structuring, cutting high-reflectivity metals, microwelding, sintering, and engraving, as well as remote processing and directed-energy applications.

“[IPG’s] multimode YLS ytterbium-doped CW fiber lasers span a power range from 1 to 100 kW and can be manufactured up to several hundreds of kilowatts upon customer request,” says Markevitch. “Their many uses include cutting, drilling, brazing, welding, annealing, heat treating, and cladding. With continuous improvement in their design, wall-plug efficiencies of standard industrial YLS system have now reached over 40%, and the industry record YLS-ECO series has a WPE exceeding 50%.”

The same multimode YLS lasers are used for both high and low-brightness applications such as welding, drilling, and precision cutting—“a previously unheard of capability,” Markevitch says. “The high brightness allows the use of long-focal-length processing lenses for vastly improved depth of field and minimal damage to optical components.”

While high-brightness multimode lasers dominate in materials-processing applications, single-mode kilowatt-class CW lasers are gaining increasing attention, as they enable new applications that require high CW peak power with very small spot sizes and/or remote processing capability. Some applications of YLS-SM lasers described by Markevitch include high-speed slitting of stainless metals for sieves and filters, remote cutting of anode and cathode battery foils, remote and gas-assisted high-speed cutting of copper (Cu) and aluminum (Al) foils, and high-aspect-ratio narrow welding for minimal distortion of thin metals.

One particular example of kilowatt-class CW single-mode laser use highlighted by Markevitch is microstructuring of cast-iron and aluminum engines in the automotive industry. Environmental regulations requiring lower energy consumption as well as reduced pollution and carbon dioxide emissions create demand for thinner, lightweight engines. A new design for motor blocks with

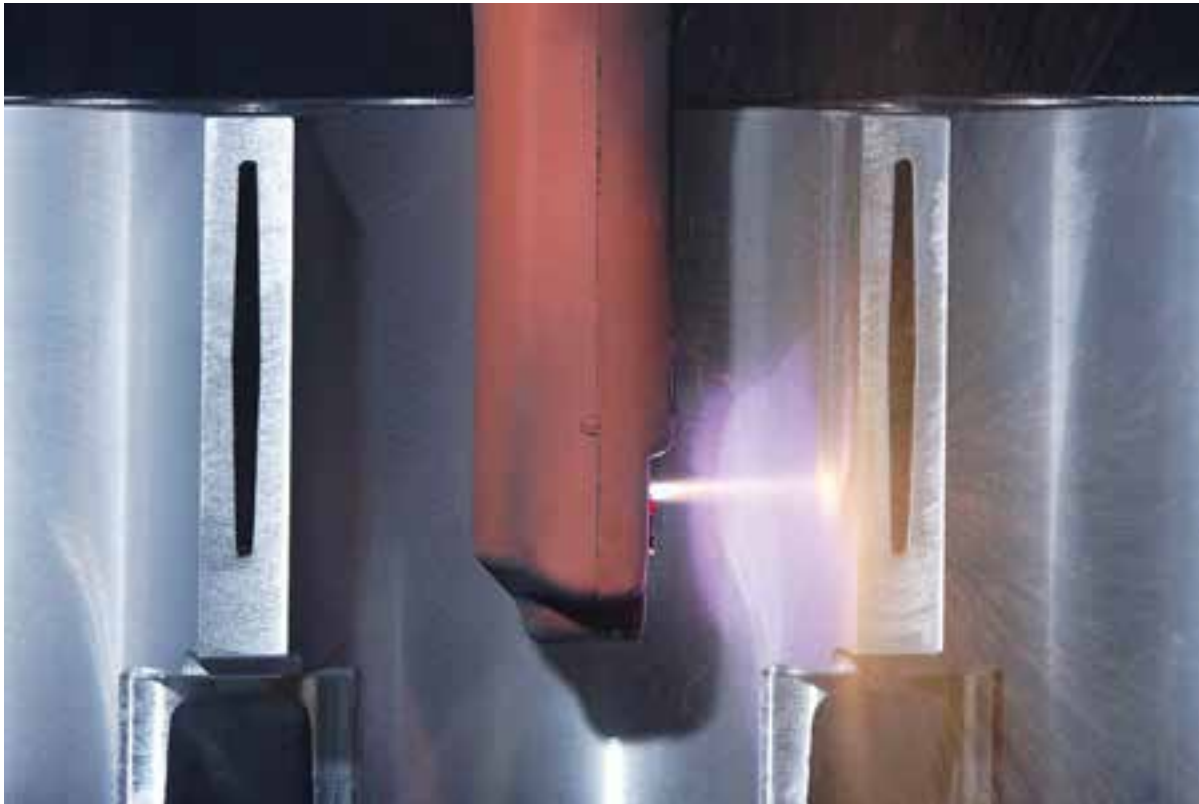

FIGURE 1. The cylindrical surface of a bore for an automobile engine is micromachined using a 2 kW single-mode fiber laser from IPG Photonics, then sprayed with plasma to create a hard coating that replaces conventional cylinder liners. Laser-machined microgrooves help the resulting coating to adhere to the cylinder. (Courtesy of IPG Photonics)

reduced wall thickness, aided by laser materials processing, results in 1 kg weight savings per cylinder.

To achieve higher mechanical resistance and optimize heat conductivity, the cylinders are sprayed with thin plasma coatings (see Fig. 1). Prior to the application of the cladding, the cylinder surface is microstructured with grooves that have a typical feature size of 100 μm or less.

Such surface structuring has traditionally been done by mechanical or water-jet processing. These legacy technologies have various drawbacks. For example, mechanical processing is slow, can be done only perpendicular to the surface, and requires a change of tools for processing different parts and groove sizes. A water jet has very high power consumption (120 kW per nozzle) and high water consumption (contaminating water with Al), creates a sponge effect in Al, requires drying in a vacuum chamber, and can only be done on Al parts.

“A single-mode YLS-2000-SM laser with nominal power of 2 kW can treat both iron (Fe) and Al parts, is easily adaptable to treatment of parts of different diameter with grooves of different sizes down to 30 μm , and has a maximum power consumption of 5.5 kW,” explains Markevitch. “Different groove angles are also possible. Both quality and throughput are much improved over traditional technologies.”

Modular design

Erik Zucker, senior director of laser products and technology at Lumentum (Bloomfield, CT) describes both the modular nature and the inner workings of the company’s Corelight kilowatt-class CW fiber-laser line. “Our basic building block is a double-clad fiber, single-oscillator module with over 2 kW output power,” he says. “Several of these modules may be combined to provide significantly higher power from a single beam. Our fiber lasers are predominantly used for 2D sheet-metal cutting of materials ranging from mild and stainless steels to aluminum, copper, and brass. They can also be used for metal welding, brazing, and cladding applications.”

The 2 kW fiber-laser module is made up of a single fiber oscillator that is end-pumped by an array of Lumentum’s ST Series high-brightness, fiber-coupled laser

diodes, which are designed and manufactured in-house, notes Zucker (see Fig. 2).

“Each pump produces 140 W of output power from a 106- μm -diameter fiber at over 50% wall-plug efficiency,” he explains. “Multiple pump fibers are fusion-combined together into a single fiber, which in turn is spliced to one end of the oscillator. Fiber Bragg gratings define the cavity and output coupler. Because the 2 kW is produced from a single module, the beam-parameter product (BPP) is very low, typically 0.8 mm-mrad. This allows a small spot diameter with large depth of field to be focused on the workpiece in metal-cutting applications, which in turn creates a very high intensity and leads to extremely efficient cutting.”

Zucker notes that 25-mm-thick mild steel can be cut with the 2 kW output from Lumentum’s fiber laser, whereas a 4 kW CO₂ laser can only cut steel up to a 22 mm thickness. The low BPP leads to fast cutting: for example, 1-mm-thick aluminum can be cut at 75 m/min with 4 kW, while the 6 kW version cuts 1-mm-thick stainless steel at 94 m/min.

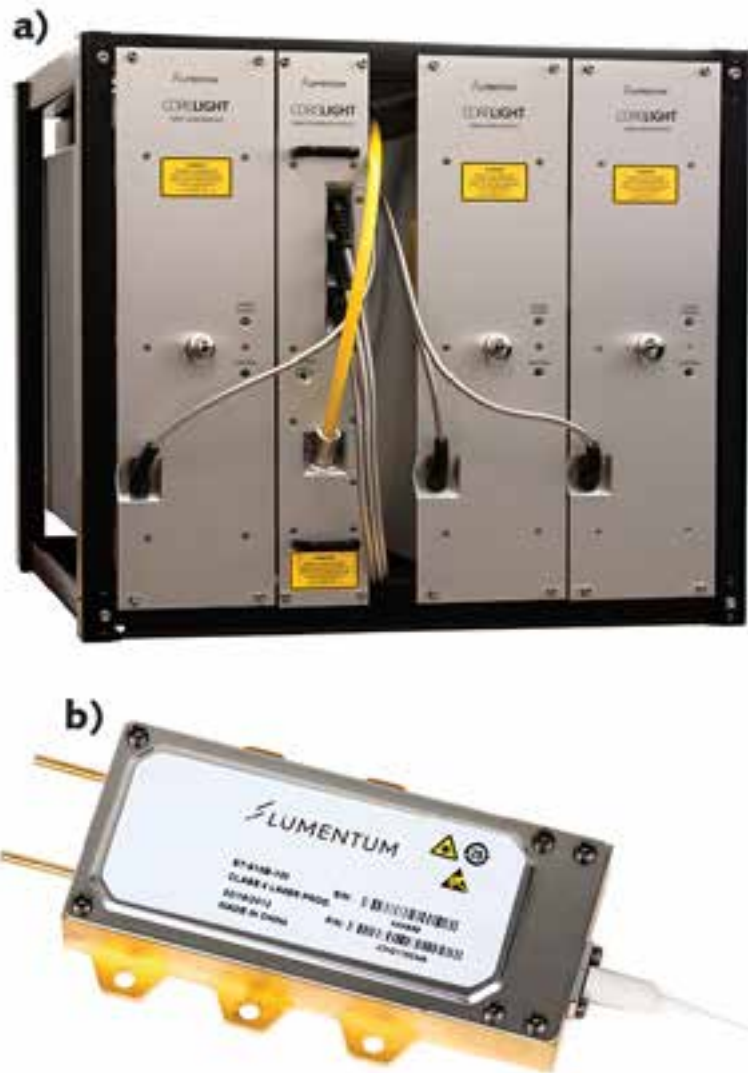

FIGURE 2. A 6 kW Lumentum fiber laser consists of three 2 kW modules and a fiber-combiner module (a). The lasers are pumped with the company’s ST Series high-brightness fiber-coupled laser diodes (b). (Courtesy of Lumentum)

Amada (Kanagawa, Japan), a development partner and customer of Lumentum, incorporates the 2 kW laser into its cutting tools. One feature enabled in part by the low BPP of the 2 kW laser is called ENSIS, which allows on-the-fly electrical adjustment of the beam spot size on the workpiece. For automated cutting jobs, says Zucker, ENSIS can adjust from thin to thick metal cutting without operator intervention, improving productivity at job shops.

Getting the light to the workpiece

Rofin-Sinar Laser GmbH (Hamburg, Germany), which makes CW high-power fiber lasers (FL Series) ranging from 500 to 8000 W in output power, provides a number of ways to get light from the laser to the workpiece. The company's lasers can be supplied with either direct-spliced fiber of single-mode or multimode beam quality, or with a fiber-to-fiber coupler or fiber-to-fiber switches of multimode beam qualities, which allow the user to plug up to four fibers for sequential or parallel beam use, says Wolfram Rath, product manager laser sources at Rofin.



FIGURE 3. A Rofin scanner-based fiber laser welds automotive parts. (Courtesy of Rofin-Sinar)

The spliced version is more compact, with a single cabinet, while the switched version has a separate enclosure for beam management. The lasers are used for cutting, welding, and surface treatment, as well as for a variety of scanner-based applications that are supported by integrated scanner processing.

The FL Series fiber lasers use a large-mode-area double-clad fiber as their active medium, says Rath. “These consist of an active single-mode core and a cladding with large diameter, in which the pump beam is conducted,” he notes. “The pump light from long-life pumping modules is fed to the cladding from both sides by means of pump couplers. They are passively cooled, tolerating individual single faults, and can be exchanged in the field if necessary. The resonator mirrors are formed by inscribed fiber Bragg gratings (FBGs).”

The laser reaches an output power of 2.4 kW from a single fiber laser module, with a nominal power of 2 kW. Up to four fiber laser units can be combined by an all-fiber power combiner for a total nominal power of 8 kW, which can be delivered by up to four 100- μm -core-diameter process fibers to the processing cell.

These high-power fiber lasers are a standard tool for metal laser cutting and welding within the macro application branch, says Rath (see Fig. 3). Standard cutting systems are typically equipped with compact fiber lasers having direct process fiber of 50 μm or 100 μm core size depending on the power and sheet-thickness range of the cutting systems. “Welding of automotive parts is realized frequently within several workstations that are connected to the laser by different fiber cables that can be as long as 100 m,” Rath says. “This setup helps to minimize the cycle times and optimize the laser utilization. For example, the parts are assembled and clamped in station ‘A’ when the laser is welding a second workpiece at station ‘B.’”

Because the fiber laser can be adapted to the application by choosing the fiber size, the same laser can be used for different operations. For example, manufacturing of an automotive part is done using three different laser-processing methods that are performed subsequently in three working cells: coating removal (performed using a high beam quality and integrated scanner processing), cutting of an aperture for perfect fit, and welding.

Back-reflection isolation

Kilowatt-level industrial fiber lasers that perform operations on highly reflective materials are faced with the problem of back reflection, where light reflected from the laser optics' focal region on the workpiece passes backward through the laser system. "Typical back reflections are only a fraction of the laser power because of work-piece surface irregularities, lack of precise alignment with the surface normal, and the limited collection angle of the process optics; furthermore, in many cases the back reflection has a short duration (for example, piercing)," says Jake Bell, general manager at nLIGHT (Vancouver, WA). "Nonetheless, the design of some fiber lasers renders processing of reflective materials difficult or impossible."

nLIGHT produces a series of materials-processing fiber lasers with power levels ranging from 500 W to 4 kW. Among other attributes, the nLIGHT alta series has a unique configuration to minimize back reflection. "Damage caused by back reflections usually results from deposition of optical power into polymer materials, which overheat and burn," explains Bell. "The nLIGHT alta strips the back-reflected light coupled into the feeding fiber and directs it to a water-cooled beam dump where it is converted to heat

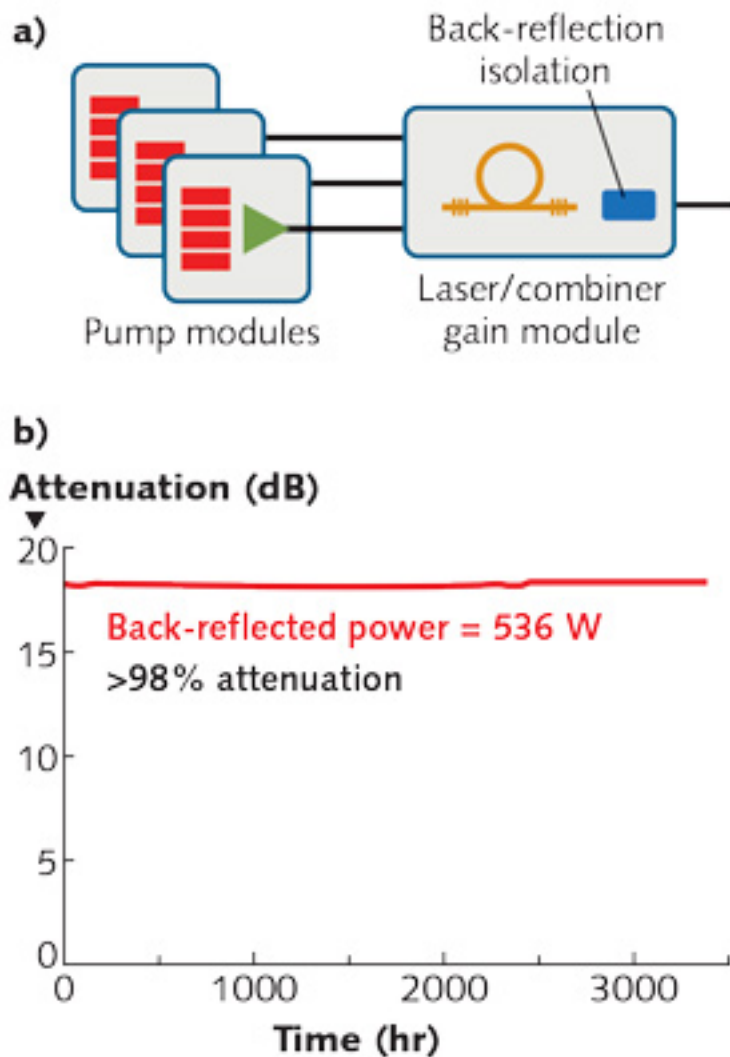

FIGURE 4. The nLIGHT alta design incorporates a back-reflection isolator between the laser and delivery fiber (a). A continuous laser-stability stress test with greater than 500 W directed back into the laser for thousands of hours shows no indication of unstable operation (b). (Courtesy of nLIGHT)

without any interaction with polymers, thereby eliminating the primary damage mechanism. The polymer-free isolator is designed to dump more than 500 W continuously (see Fig. 4).”

Bell says, “We evaluated the performance of the isolation system in the case of piercing, where the highest back-reflection signals occur in laser cutting. The test successfully processed 4000 consecutive pierces of copper with no interruptions or failed pierces. In contrast to the robust, hardware-based protection provided by our back-reflection isolator, some other fiber lasers employ software protection that disables the laser in the case of a back reflection; this approach may protect the laser, but it precludes successful continuous materials processing.”

The back-reflected light that is dumped in the isolator is monitored using a photodiode, says Bell. The real-time output of this sensor is provided to the user for use in process monitoring, optimization, and control (for example, pierce detection) or for tool calibration (such as beam position and focus).

Other qualities of the nLIGHT alta lasers outlined by Bell include improved cutting and welding performance, in which the lasers can deliver a modulation rate up to 100 kHz and a rise and fall time of less than 5 μ s. These capabilities allow faster piercing, faster processing of fine features, and better processing quality through minimal heat affected zone, he says.

“Most multi-kilowatt fiber laser systems employ an architecture based on combining the outputs of multiple, lower-power fiber lasers, resulting in significant shortcomings in cost, performance, serviceability, upgradeability, and amenability to technological advances,” he adds. “We introduce a novel kilowatt fiber-laser architecture that solves these problems by housing the pump diodes and drivers in standalone pump modules and the gain fibers in a configurable gain module that can generate more than 4 kW of output power.”

These lasers, which have tailorable beam quality ($BPP \geq 1.1$ mm-mrad), have been used for high-quality cutting and welding of mild steel, boron steel, stainless steel, aluminum, brass, and copper, and have also been employed in emerging applications that include additive manufacturing and surface texturing and engraving.

Quick component replacement or upgrade

As described by Frank Gaebler, marketing director for materials processing at Coherent (Santa Clara, CA), first-generation fiber lasers were based directly on telecom platforms massively scaled to higher power, using a large number of separate pump laser diodes, each independently fiber coupled and permanently spliced together.

“This brute-force approach to higher power has several limitations,” he says. “In particular, all the components are permanently spliced together. If one component fails or degrades, there is no way to replace it. For example, early models were found to be susceptible to back reflections from metal processing. If the fiber splices, pump diodes, delivery fiber, or any other laser component is damaged by such back reflections, the laser had to be factory-repaired or exchanged, negatively impacting uptime and net production.

Coherent makes a second-generation kilowatt-scale fiber platform (the Highlight FL) based on a flexible modular architecture (see Fig. 5). Engineers at Coherent

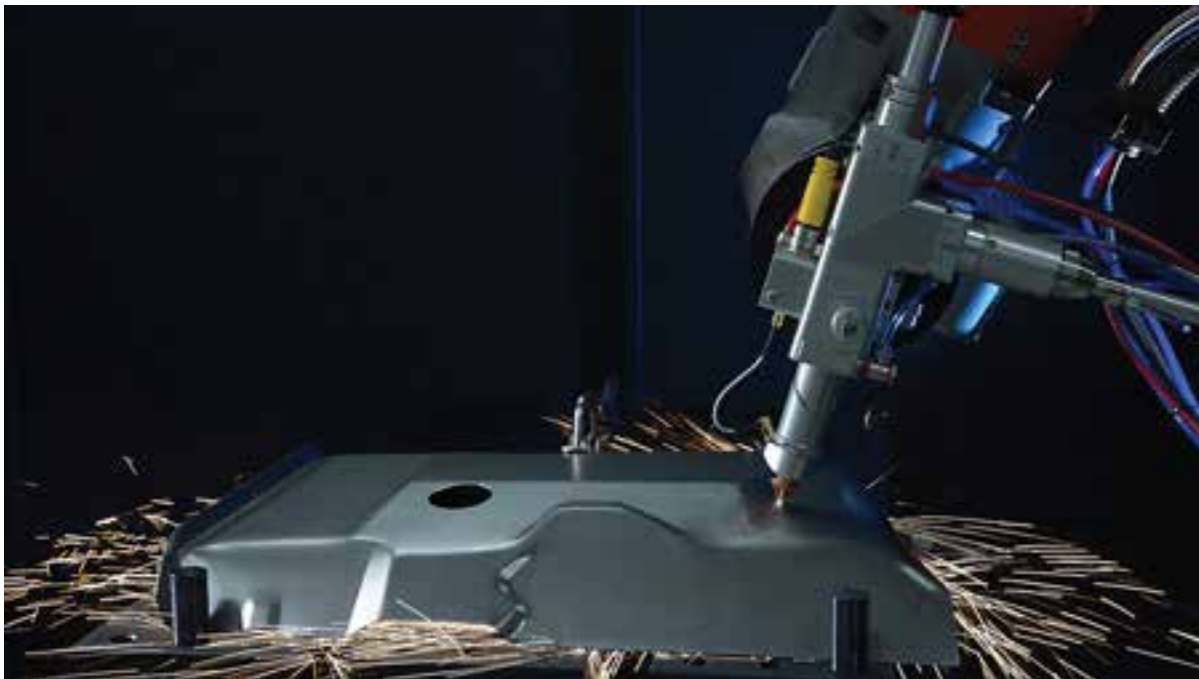

FIGURE 5. A Coherent Highlight FL fiber laser can be combined with robotics to enable high-speed 3D part cutting for industries such as white goods (washing machines, kitchen stoves, and so on). (Courtesy of Coherent)

have used a substantially different design approach that eliminates the complexity of multiple pumps and splices, with a modular architecture that also enables simple replacement and/or upgrade of the various components, including the delivery fiber, notes Gaebler.

We use fiber-coupled high-power laser-diode bars rather than multiple separate laser diodes,” he says. “Their output is then coupled into the gain fiber using free-space coupling; this coupling module is also used to connect the gain fiber to the detachable delivery fiber.” He adds that this approach is particularly attractive to OEM system builders, as they can buy complete lasers or separate modules depending on their level of expertise or requirements for deep integration, and they can quickly change or replace the delivery fiber to suit different applications.

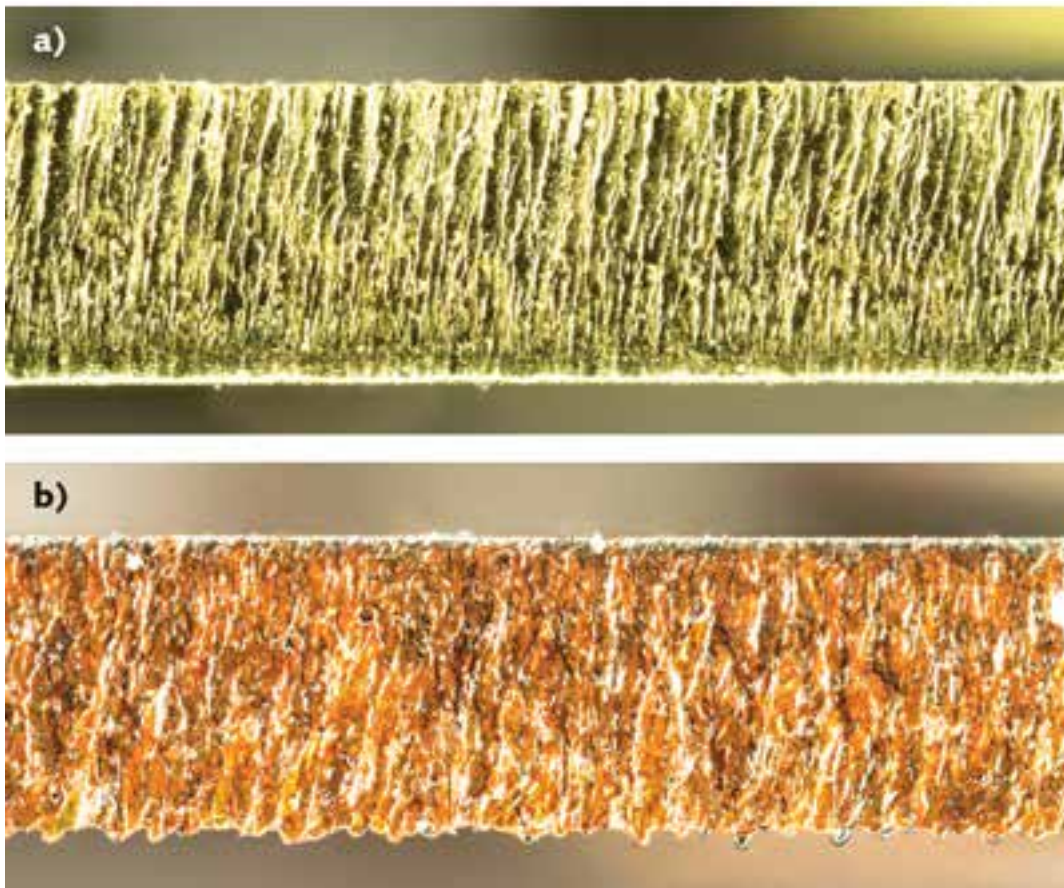

FIGURE 6. Immunity from back-reflections enable cutting of highly reflective metals that were problematic for first some-generation fiber lasers. Cross-section views show cuts created by a Coherent Highlight FL laser through 1.25-mm-thick brass (a) and 1.2 mm copper (b). (Courtesy of Coherent)

In terms of specifications, at present, Coherent's Highlight FL fiber lasers are targeting steady increases in maximum power, says Gaebler: the latest model delivers 3 kW with an increase to 4 kW expected sometime in 2016. "At present, our delivery fiber modules are available with a 100 μm core, which corresponds to a BPP of around 4 mm-mrad," he says. "A 50- μm -core delivery fiber has recently become available for some models that can achieve a reduction in BPP of up to 2X. As a result of their high power and low BPP, these HighLight FL lasers are well-suited for processing metals ranging in thickness from thin foil to a few millimeters."

Companies mentioned in this article include:

Coherent

Santa Clara, CA
www.coherent.com

nLIGHT

Vancouver, WA
www.nlight.net

IPG Photonics

Oxford, MA
www.ipgphotonics.com

Rofin-Sinar

Hamburg, Germany
www.rofin.com

Lumentum

Bloomfield, CT
www.lumentum.com

For a complete listing of companies making high-power fiber lasers, visit the *Laser Focus World* Buyers Guide (<http://buyersguide.laserfocusworld.com/index.html>).

Early fiber lasers sometimes struggled to cut, drill, and weld certain metals, notes Gaebler. For example, fiber-laser fundamental output wavelengths are usually around 1 μm . This is a wavelength region where brass and copper exhibit very high reflectivity, as evidenced by the extensive use of copper mirrors for beam delivery of near-infrared lasers of all kinds. Retroreflections have made these metals a significant challenge for machining with first-generation fiber lasers.

According to Gaebler, unlike first-generation fiber lasers, the Highlight FL laser architecture is immune to back-reflection damage for two reasons: 1) the geometry and optical properties of the dichroic beam combiner mean that any back reflections cannot reach the pump diode bar; and 2) there are no fiber splices to be damaged by any back reflections. As a result, the lasers are not limited by qualifiers that urge extreme caution with reflective metals (see Fig. 6).

Beam Characterization:

High-power fiber lasers drive noncontact-measurement techniques

The beam focus of high-power fiber lasers can be characterized via imaging of Rayleigh scattering in air—an indirect detection method that avoids damage to detectors due to ultrahigh-power beams.

By **KEVIN KIRKHAM**

JOHN WILLIAM STRUTT was born on Nov. 12, 1842, in Essex, England. His father was the second Baron of Rayleigh, and upon his death, Strutt became the third Baron of Rayleigh. In 1871, Lord Rayleigh explained that the sky was blue because shorter wavelengths of light are more easily scattered by the gas molecules that make up our atmosphere (see Fig. 1). Longer wavelengths are similarly scattered but at a statistically lower amount (inversely proportional to the fourth power of the wavelength).

Lord Rayleigh could not have predicted the uses of the scattering phenomenon he described; Rayleigh scattering has shown to be an excellent way to monitor the performance of high-power lasers and the optical delivery systems used to bring the beams to the workpiece.

Since the early 1960s, the fiber laser has held the promise of an inexpensive coherent light source that can easily be brought to the workpiece. These workpieces can now include the human eye (via laser surgery), a sheet of steel

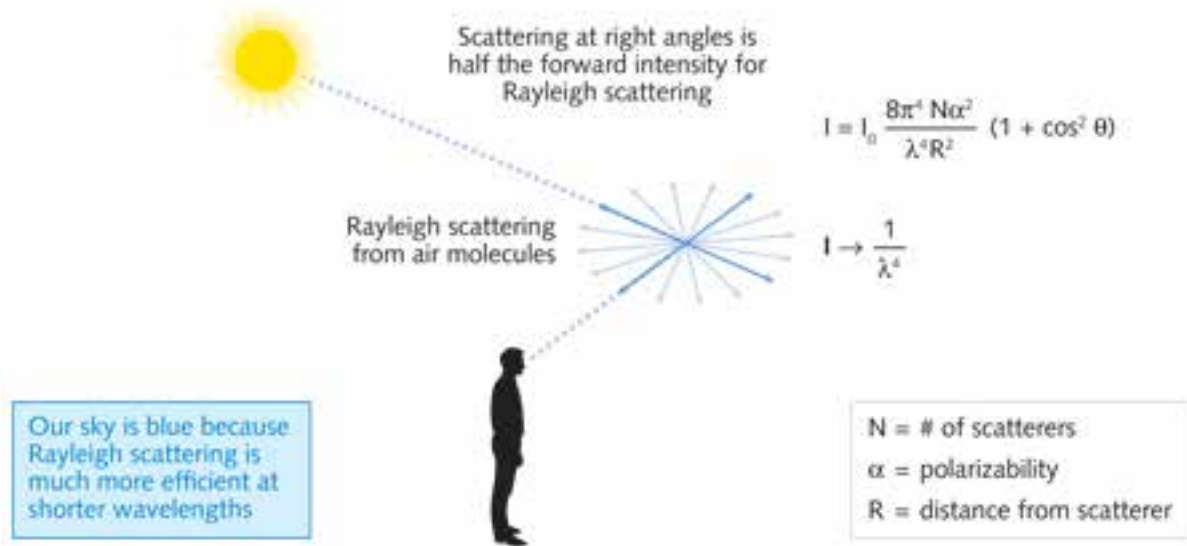

FIGURE 1. Rayleigh scattering of light from molecules in the air scales inversely with the fourth power of the wavelength.

(via industrial laser cutting and welding) or an enemy rocket (via military lasers now in development), among countless others.

With the advent of cladding pumping, ytterbium (Yb)-doped fibers, and high-power/high-brightness diodes, modern high-power fiber lasers have become an impressive reality. Fiber-laser architecture is modular, permitting a near-limitless amount of total power to be realized by combining the output of multiple modules. In one example, IPG Photonics (Oxford, MA) recently installed a record 100 kW materials-processing fiber laser for Japanese joining technology supplier NADEX (Nagoya City, Japan).

Measuring high-power lasers

All laser processes benefit from the use of diagnostic equipment, if only to assure the operator that the laser and laser beam delivery components are still operating as expected. Of course, the ability to effectively monitor any process is a necessary precursor to mastering that process.

More and more applications require fiber-laser parameters to be optimized and consistent. Predictable and desired outcomes can be better assured by providing accurate, repeatable laser performance to the workpiece. Parameters important

for efficient laser processing of the product or process include: beam intensity, waist size, and waist location of the X, Y, Z process volume. Most important is the ability to provide stable processing profiles of these measurements over time.

Compounded laser measurements, such as beam quality (m^2) and beam parameter product (BPP), are other ways of defining or predicting the primary laser-processing parameter, which is spot brightness. Commercial beam-monitoring systems use beamsplitters, waveguides, or scanning slits to sample and attenuate high-power lasers.

While these systems are practical in that they use these sampling techniques to effectively match the sampled laser-beam intensity to the usable range of the profiling sensor, the sampling techniques add some distortion and uncertainty to the measurement data. Traditional diagnostic techniques measure one or two parameters at once, providing a myopic view of laser performance and argue the need for a number of diagnostic tools to be used sequentially or in tandem.

Laser-beam diagnostics have always included a way to measure the intensity of the beam—either the average power or the energy of each laser pulse. This is accomplished using thermopile and quantum-type sensors to measure the average power or with pyroelectric sensors to measure the energy per pulse.

More recently, ways to monitor the laser mode or beam profile have become available to provide greater knowledge of the laser system's performance to the operator. These systems consist of scanning-slit or CCD/CMOS-camera sensors that measure the beam's 1D or 2D intensity distribution. These systems are also capable of measuring the location of the focused spot or minimized beam in the processing zone. Optimally, beam-profiling systems should indicate how the power density changes across the area of the focused spot.

More complex systems that measure M^2 , BPP, divergence, and mode-field diameter are now available. These systems are based on beam profilers that can translate the spatial-measurement setup along the beam-propagation axis. This results in a more complete understanding of laser performance. This toolbox approach to monitoring multiple laser characteristics is possible but not always practical, and certainly not effective in a manufacturing environment.

Most current techniques require the beam to be optically sampled; anything placed in the beam will cause some amount of distortion to the sampled beam as well to the working beam. Focused multikilowatt fiber lasers achieve power densities of many megawatts per square centimeter. Thermal lensing of the sampling optics and the potential for damage of transmissive optics push traditional beam-sampling techniques to their limit and expose the diagnostic system to ultimate failure.

Noncontact beam measurement

We have developed a Rayleigh-scatter-based profiler that provides instantaneous measurements of spot size, focal-spot location, focal-plane shift in the propagation and lateral axes, and m^2 and BPP measurements. This beam profiler, BeamWatch, can assess lasers that have power densities of 2 MW/cm² or greater without requiring any optics or waveguides to be placed in the beam path. Because no optic interacts with the beam, there is no practical limit to observable power densities.

The profiler uses a CCD camera to image the laser path over a distance of more than 25 mm as it propagates through focus. The camera frame rate permits the focal plane, and thus any focal-plane shift, to be continuously monitored in ≤ 40 ms intervals.

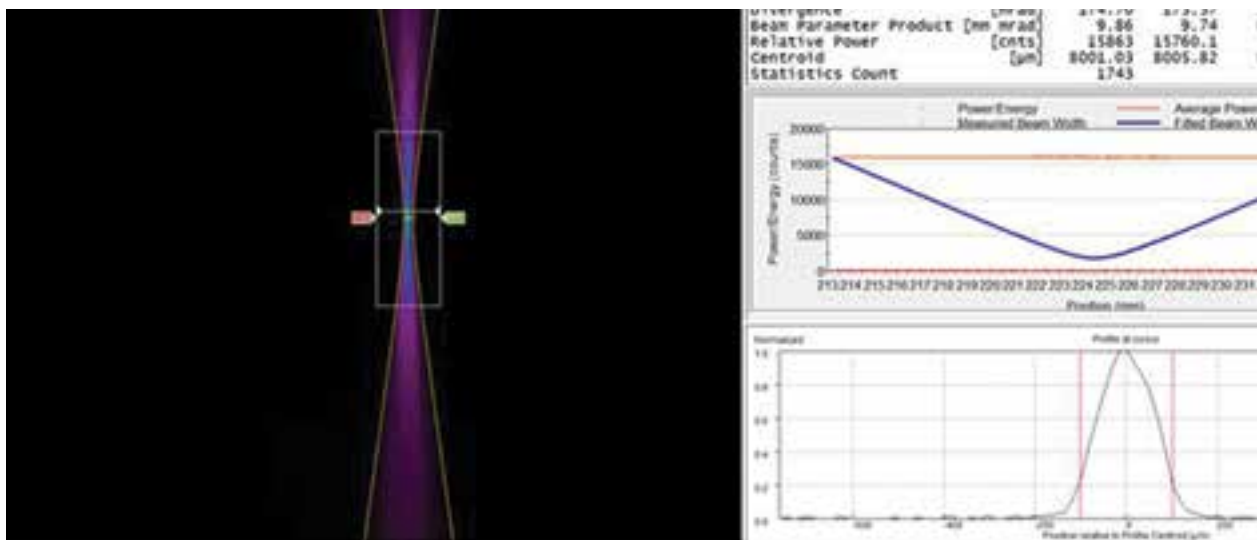

FIGURE 2. The operator screen for the BeamWatch Rayleigh-scattering-based beam profiler displays the beam along with its relevant parameters. (Courtesy of Ophir Photonics)

The operator screen displays the beam caustic in false color, along with the initial and current focal plane location. Calculated results include m^2 , waist width, waist location, focal-plane shift, divergence, BPP, power, and centroid location (see Fig. 2). These measurements

can be analyzed to test if they fall within a pass/fail window. Results that fall outside of the predefined minimum-maximum windows are immediately enunciated and the operator alerted.

Recently, this Rayleigh-scatter-based fiber-laser measurement device and Ophir's 100 kW calorimeter-based laser-power sensor were used to monitor the output of IPG Photonics' 100 kW laser (see Fig. 3).

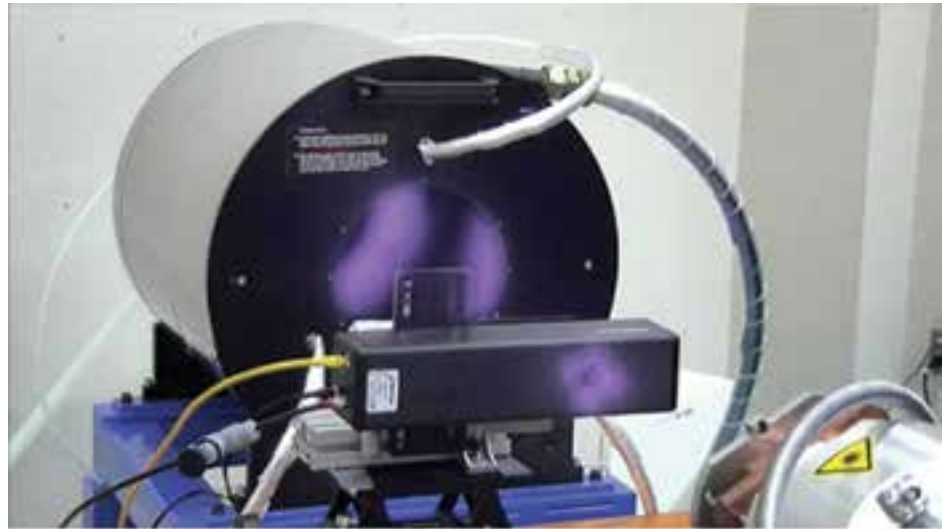

FIGURE 3. The beam power and profile of a 100 kW fiber-laser beam are measured at the same time via the combination of a calorimeter-based power sensor and Rayleigh-scattering beam profiler. (Courtesy of Ophir Photonics)

.....

KEVIN KIRKHAM is regional sales manager at Ophir-Spiricon LLC (North Logan, UT); email: kevin.kirkham@us.ophiropt.com; www.ophiropt.com.

Fiber Lasers:

Multiple laser beam materials processing

Fiber lasers producing different spot sizes, pulse durations, or wavelengths can be combined into a single process for applications such as brazing, welding, and surface texturing.

By **TOBY STRITE, ANDREAS GUSENKO, MICHAEL GRUPP, and TONY HOULT**

MANUFACTURERS VIEW LASER material processing as a mature, well-understood productivity enhancement, which they constantly seek to extend to new segments of their business. Lately, that search has produced a trend toward the deployment of multiple laser beams on a single workpiece, each optimized to perform a facet of the overall process. This trend is already undergoing rapid adoption in automotive manufacturing, and we believe it will soon impact other fields.

This article highlights three examples of multiple laser beam processing. To begin, we show how trifocal brazing utilizes coordinated beams to join automotive materials with high strength and superior cosmetics. Next, we examine the benefits of a two-step welding process for high-strength steel, in which a laser cleaning step enables laser welds of outstanding strength and integrity. Our final example highlights how laser surface texturing of a metal enables high-strength, hermetic polymer-to-metal bonding. These examples highlight the possibilities available when multiple laser beams of differing diameter, pulse durations, or even wavelength are coordinated to produce previously unobtainable results.

Trifocal brazing

The automobile industry relies of the unique ability of lasers to provide high joint strength with minimum material usage, at the same time promoting safety and fuel economy. While laser welding is entrenched within the automobile, a more cosmetic process is preferred in visible joints along the roofline and car sides. In contrast to welding, brazing is a technique that does not melt the surfaces to be joined. Rather, for automotive applications, laser energy melts a wire to form a cohesive joint between two steel or aluminum surfaces. Automakers desire a brazing process that requires just a light brushing prior to the application of paint to realize a truly seamless joint.

Brazing studies on electro-galvanized low-carbon steel link joint quality and aesthetics to edge variability. In particular, oxides and contaminants residing on the thin zinc (Zn) anti-scaling layer are the main causes of spatter and edge roughness. This knowledge inspired the development of a novel three-beam brazing system in which two lead beams travel along the steel edges ablate contaminants and pre-heat the Zn surface layer to promote wetting. The powerful trailing beam supplies energy to melt the Cu/Si wire to seamlessly join the newly cleaned steel surfaces (see Fig. 1).

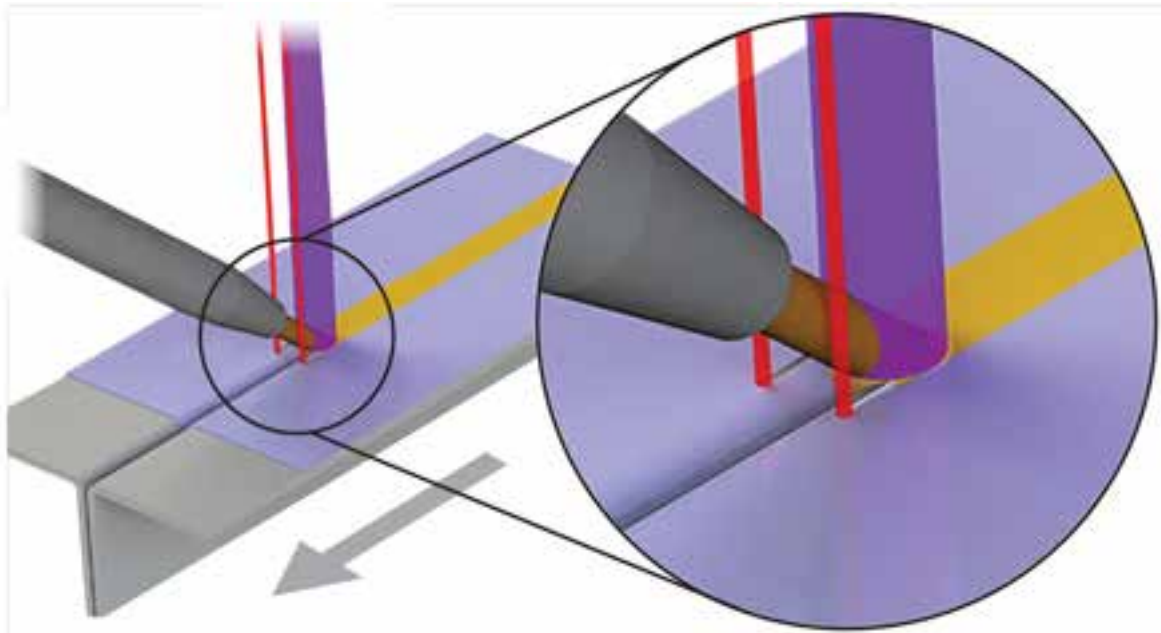

FIGURE 1. In trifocal brazing, two lead beams (red) clean and pre-heat the steel edge surfaces to promote wetting. The trailing beam (purple) melts the Cu/Si wire to form a seamless brazed joint which, after painting, can be invisible to the naked eye.

The trifocal brazing system relies on the flexibility of fiber technology (see Fig. 2). Fiber lasers are coupled into three optical fibers of different diameter, which are delivered through a single cable. Near the workpiece, the delivery optic creates the desired three-beam profile, allowing the narrow lead beams to pre-clean before the trailing beam completes the spatter-free brazed seam.

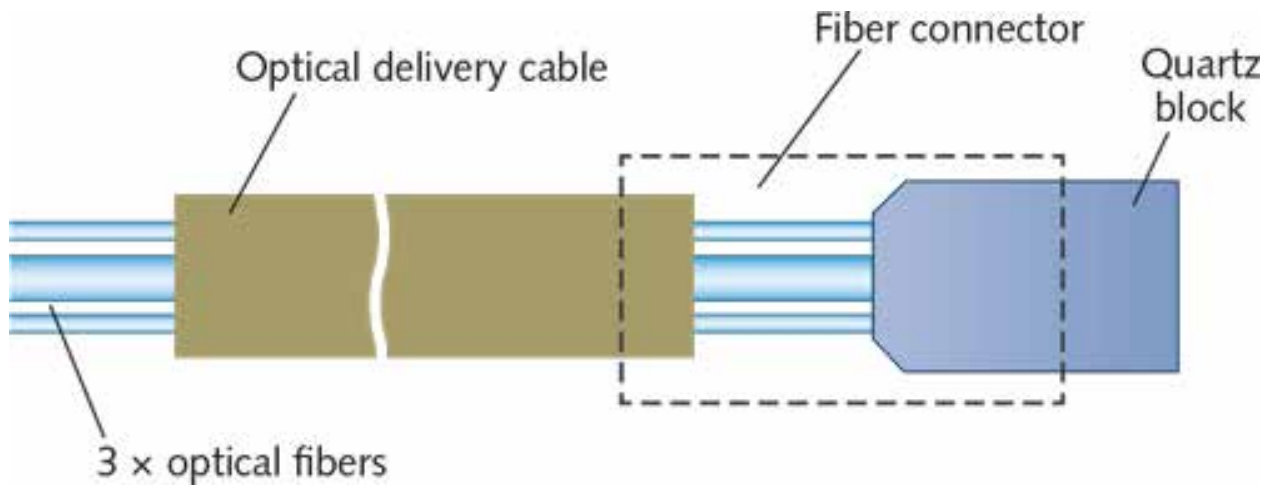

FIGURE 2. Three fiber core trifocal brazing optics enable different diameter fibers to pass through a single process cable to deliver spatially offset spots of different size to the brazing area.

To directly assess the benefits of trifocal brazing, a near-infrared (NIR) fiber laser was used to join a series of 0.8 mm hot-dipped steel samples using 1.6 mm CuSi3 alloy wire with a 3.5 kW infrared brazing beam at a process rate of 4.5 meters per minute. When 350 W lead beams are added to pre-clean the steel edges prior to melting the copper silicon (CuSi) wire, greater edge uniformity and a better surface finish are readily observable (see Fig. 3).

Trifocal brazing combines cleaning and joining in a single process, greatly reducing post-processing requirements before painting. The brazing can be fully automated at high speed with excellent joint strength and reproducibility along straight and curved borders. Automakers are increasingly adopting trifocal brazing as their preferred solution for cosmetic steel joints to optimize both productivity and aesthetics.



FIGURE 3. A comparison of single-spot (a) and trifocal (b) brazed seams that join steel with CuSi wire. An improved finish and suppression of edge roughness is evident in the trifocal brazing example. A cross-section (c) highlights the joint uniformity and quality obtainable with trifocal brazing.

Two-step laser welding of high-strength steel

Automakers constantly seek materials and joining methods that enable safer and more efficient vehicles. High-strength steels (HSS) bolstered by the element boron have moved to the forefront of automotive innovation, offering strength levels so great that the Jaws of Life auto rescue tool had to be re-specified in North America. Higher strength presents the opportunity to use less material for reduced vehicle weight, assuming joining technology can keep pace. Laser welding is automakers' preferred method for joining HSS. Early efforts were hampered by the aluminum silicon (AlSi) protective coatings added to avoid scaling during the hot stamping process. Brittle iron aluminum (FeAl) inter-metallic layers may result when AlSi-coated HSS is laser-welded.

Outstanding HSS weld quality is achievable when the anti-scaling coating on either side of the weld region is laser-ablated, enabling a weld between identical, clean steel surfaces free of FeAl inter-metallics. Figure 4 illustrates a clean steel surface prepared by laser ablation on which the AlSi coating is fully removed by a 1 kW, 70 ns NIR pulsed fiber laser. The ablation laser provides up to 100 mJ pulse energy (7–10 J/cm² fluence over a 1 mm² spot) delivered through a novel square process fiber to perform a precise and economical 10 m/min ablation of a 30 μm AlSi coating. Subsequent high speed welding using a multi-kilowatt continuous-wave (CW) NIR fiber laser completes the joining process, allowing strong but lightweight tailor-welded blanks to be supplied to the auto industry.

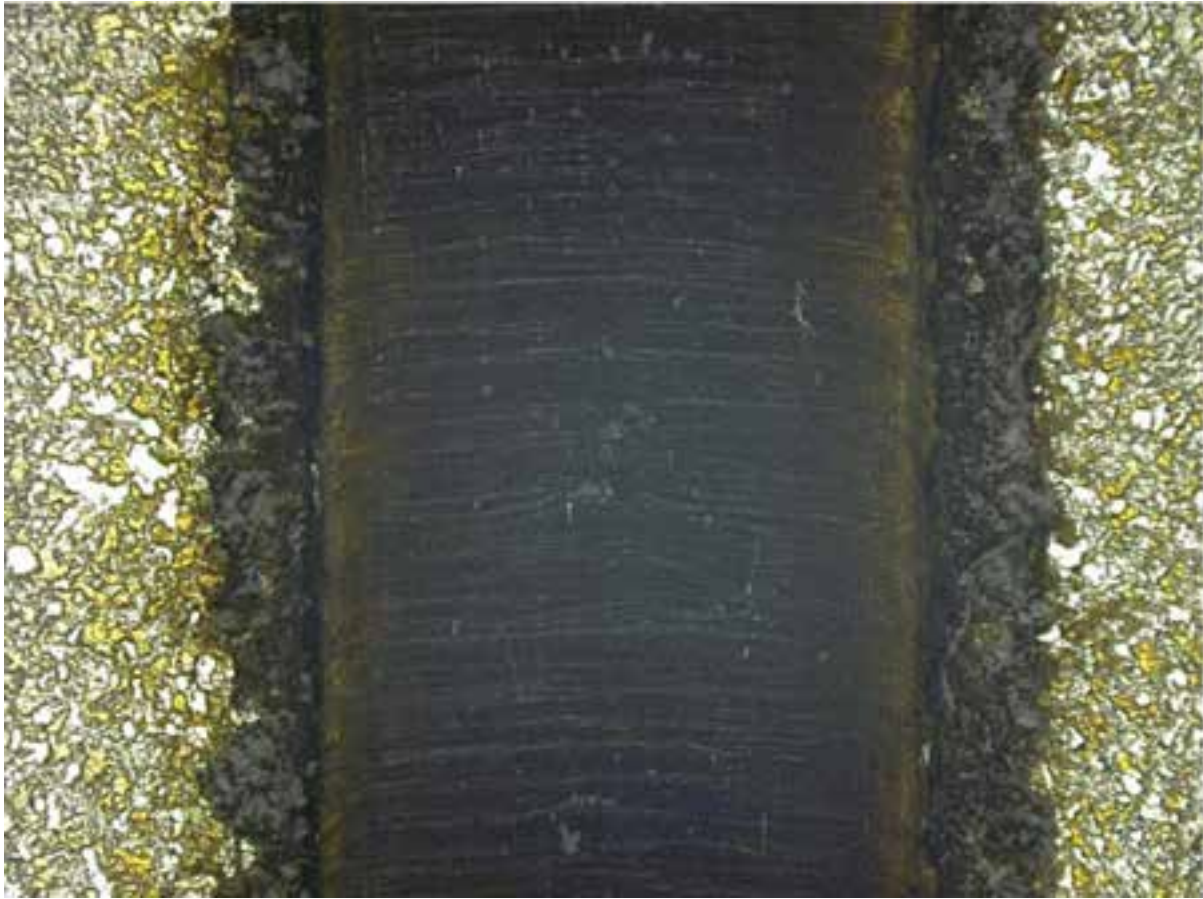

FIGURE 4. High pulse energy fiber laser technology delivered through a novel square fiber efficiently ablates the AlSi coating to expose the native HSS surface for enhanced weld quality.

In contrast to trifocal brazing, which employs two CW laser beams of different diameter, two-step welding of HSS is optimized by first applying a high-energy pulsed nanosecond ablation laser, followed by a high-power CW welding laser. Our final example also utilizes a pulsed/CW laser one-two punch, but we extend into the sub-nanosecond pulsed regime and apply two different laser wavelengths.

Polymer-to-metal joining

Welding requires melting of opposing surfaces to fuse the materials into a robust joint. Welding is widely used to join metals to metals, or polymers to polymers. However, disparate melting temperatures largely rule out polymer-to-metal welding. Effective polymer-to-metal joining remains a highly sought technology for industries as diverse as consumer electronics and medical devices. A recently developed two-step process relying on new fiber laser technology provides a promising solution.

The first step relies on a 30 W NIR fiber laser capable of 400 kW peak power when pulsed at 150 ps to provide a novel metal surface texture (see Fig. 5a). Microscopic studies suggest the high laser fluence melts a nanometer-scale surface layer, which coalesces quickly into a fine, nodular structure, one whose large surface area is ideal for subsequent adhesive bonding.

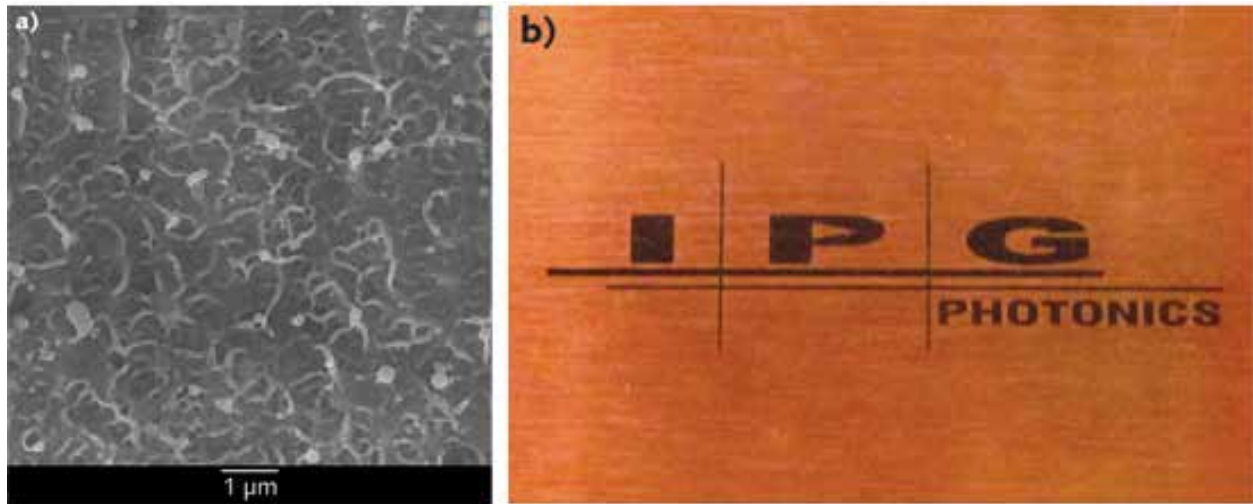

FIGURE 5. Example of the fine, nodular Cu surface structure (10,000X magnification) obtained using a sub-nanosecond NIR fiber laser (a). The textured Cu surface is perfectly black, making it an ideal absorber for subsequent laser processing (b).

What is remarkable about these textured surfaces is that they can be made perfectly black, even on highly reflective metals like Cu (see Fig. 5b). Experienced welders know that a uniformly dark surface provides the widest process window since reflectivity variations affect the threshold energy that a laser must supply to couple into a reflective metal.

Polymer-to-metal joining relies on the 1.9 μm lasing wavelength of thulium-doped CW fiber lasers. The mid-infrared wavelength is more strongly absorbed by common transparent polymers than NIR fiber laser or laser diode sources. Conventional 1 μm lasers pass through the polymer, heating only the opposing metal surface. This conducts heat into the polymer, eventually melting it into the metal to form a weak bond.

We find that polymer-to-metal bond strength is remarkably improved by first texturing and darkening the metal surface, then applying thermal energy using

the 1.9 μm fiber laser. The longer wavelength transfers heat directly to the polymer as well as the polymer-to-metal interface. The direct heating of the polymer, combined with the dark nodular metal surface, provides ideal bonding conditions. We have formed polymer-to-titanium bonds that are hermetic and so strong that they fail in the polymer when subjected to shear force.

In contrast, when the surface texturing step is omitted, lap shear tests fail at the polymer-to-metal interface, attesting to a weaker bond. Robust, hermetic joining of transparent polymers to metals opens a new degree of design and manufacturing freedom that has already generated interest among customers in fields as diverse as medical devices, consumer electronics, and low-cost consumer products.



TOBY STRITE is director of Western U.S. sales, marketing, and applications at IPG Photonics, Santa Clara, CA; **ANDREAS GUSENKO** is a product engineer specializing in automotive applications at IPG Photonics, Burbach, Germany; **MICHAEL GRUPP** is applications manager at IPG Photonics, Burbach, Germany; and **TONY HOULT** is applications manager at IPG Photonics, Santa Clara, CA; e-mail: tstrite@ipgphotonics.com; www.ipgphotonics.com.



The Challenges of High Power Lasers

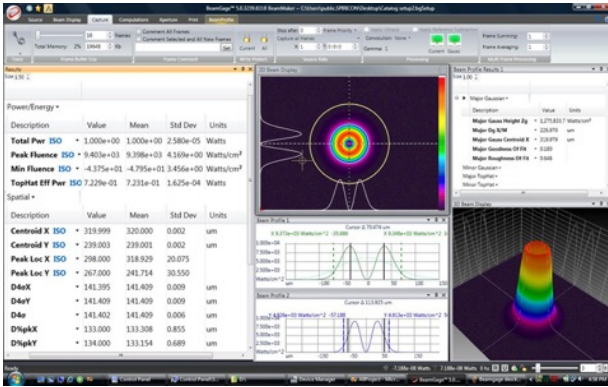

High power lasers are increasing used to mark, machine, melt, or otherwise modify materials with progressively more intricate patterns and shapes. But the higher the power, the more challenges in understanding, controlling, and measuring these small, highly focused beams.

Thus, beam profiling will play an ever more important role in evaluating high power lasers, predicting their effects on associated optics, and helping the technology reach its full potential.

WHITE PAPER: [Development of a Non-Contact Diagnostic Tool for High Power Lasers](#)

VIDEO: [Measuring Beams Coming Out of a Fiber](#)

NEW: [BeamWatch® Family of Non-Contact Industrial Beam Monitoring Systems for High Power YAG, Fiber, and Diode Lasers](#)

NEW: [Laser Power Sensor Measures High Power Lasers to 120kW](#)

VIDEO: [How to Measure Laser Spot Size and Divergence with BeamGage](#)

120K-W Laser Power Meter

Ophir Photonics
3050 North 300 West
North Logan, UT 84341 USA
+1 435-753 3729
www.ophiropt.com/photronics

