

element[®] e06

Fiber-Coupled Semiconductor Laser

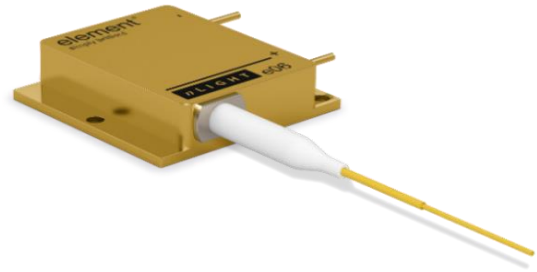

50W, 808nm, 400μm

Item Number : 1067023

	Unit	Minimum	Typical	Maximum
Optical Specifications				
CW Output Power	W		50	
Wavelength Centroid	nm	805.0	808.0	811.0
Spectral Width (FWHM)	nm		1.8	4.0
NA within 95% Power Enclosure	-		0.13	
Fiber Core / Clad Diameter	μm		400 / 480	
Fiber NA / Index Type / Cladding Type	-		0.22 NA / Step Index / Dual Clad	
Back Reflection Isolation 1060 - 1200nm	dB	15		
Electrical Specifications				
Electrical-to-Optical Efficiency	%		47	
Threshold Current	A		2.8	
Operating Current	A		10.3	12.3
Operating Voltage	V		10.4	11.5
Thermal Specifications				
Operating (Housing) Temperature ³	°C		+25	
Storage Temperature ³	°C	-25		70
Wavelength Temperature Coefficient	nm / °C		0.28	
Wavelength Current Coefficient	nm / A		0.5	
Mechanical Specifications				
Mass	g		85	
Fiber Length	m	1.4	1.5	1.6
Active Fiber Bend Radius	mm	100		
Product Information				
Item Description	-	e06-06-050-0808-3-400-0.22-SI-SMA-1.5-KL		
Fiber Jacketing	-	3 mm Kevlar Reinforced Tubing		
Fiber Termination	-	SMA		
Export Control Classification Number (ECCN)	-	EAR99		

Notes

- 1 Product image not necessarily representative of exact appearance.
- 2 Production specifications shown are for beginning of life performance at the typical operating temperature. End of life operating current (Iop) is 110% beginning of life Iop.
- 3 A non-condensing environment with relative humidity between 5 - 85% is required for operation and storage.
- 4 Export Control Classification Number (ECCN) as defined by the Export Administration Regulations (EAR).

sales@nlight.net | www.nlight.net

© nLIGHT, Inc. 2023
Rev 4/24/2023

nLIGHT

element e06

3 mm Kevlar Reinforced Tubing High Power SMA 905

Item Number : 1067023

Mechanical Drawings

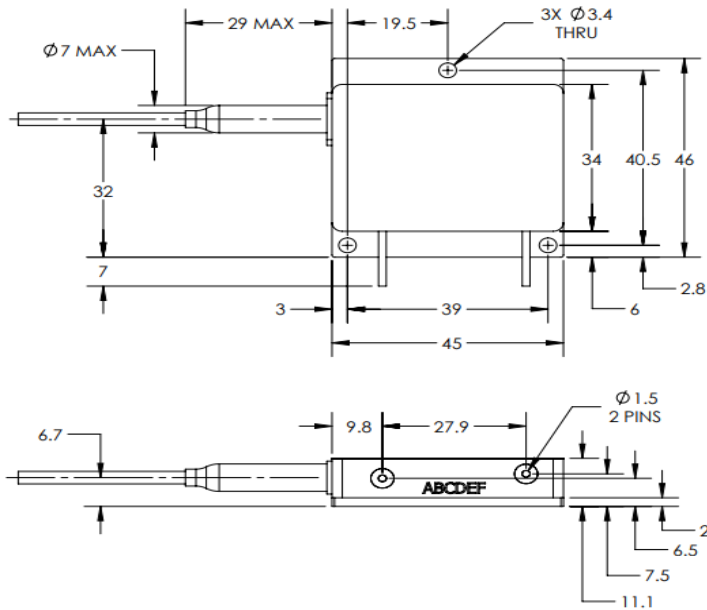

ALL DIMENSIONS IN mm WITH ± 0.25 mm TOLERANCE.

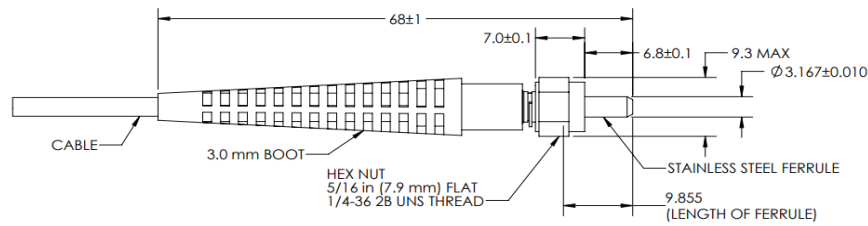
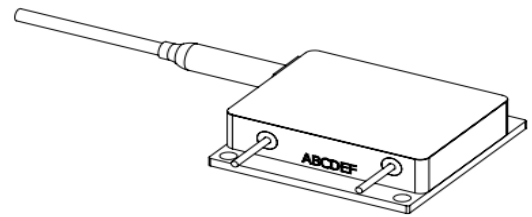

SMA TERMINATION DRAWING

nLIGHT continually improves its products to provide customers outstanding quality and reliability. The information contained herein is subject to change without notice.

This product is not certified in accordance with IEC 60825-1 or 21CFR1040.10/ 21CFR1040.11 and is solely intended to be integrated into a laser product certified by the Purchaser. The Purchaser acknowledges that their product (incorporating nLIGHT laser product) must comply with the applicable regulations before it can be sold.



sales@nlight.net | www.nlight.net

© nLIGHT, Inc. 2023
Rev 4/24/2023

